

# PORTABLE SOLAR KITS

## User Manual

GP-PSK-80

GP-PSK-120

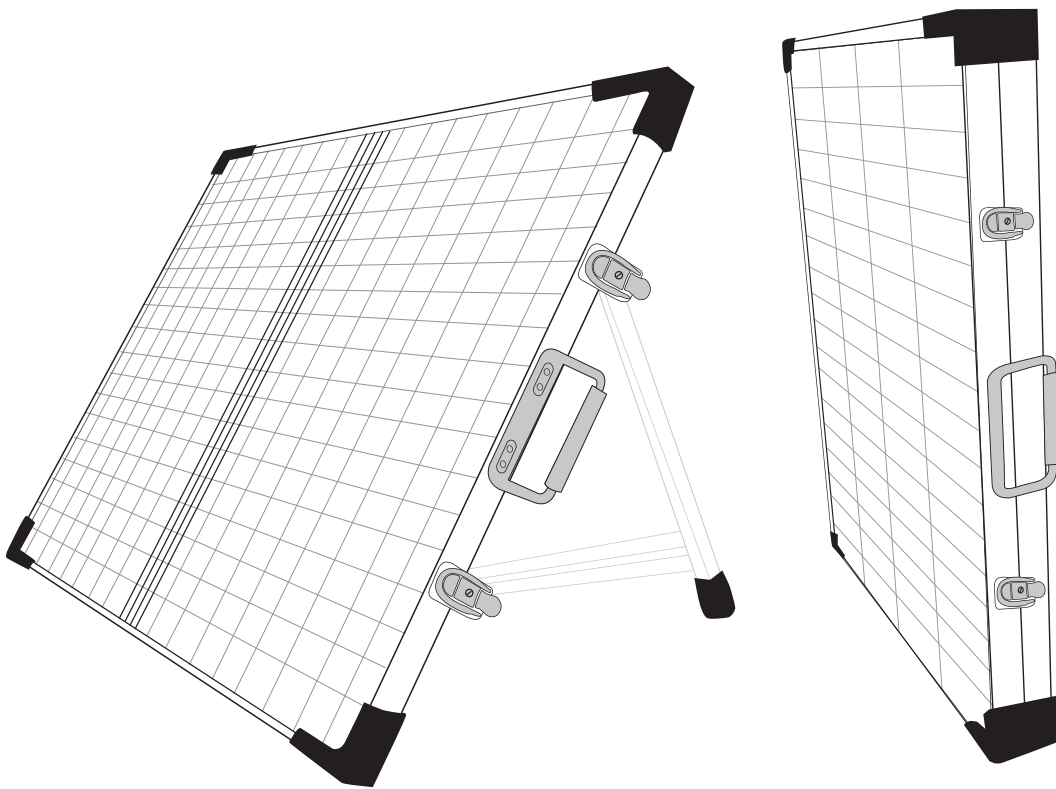

© 2016 Go Power! By Carmanah Technologies

Worldwide Technical Support and Product Information [gpelectric.com](http://gpelectric.com)

Carmanah Technologies Corporate Headquarters

250 Bay St, Victoria, BC Canada V9A 3K5

Tel: 1.866.247.6527

73807\_MANUAL\_GP-PSK\_RevH



powered by  carmanah®





2. GENERAL INFORMATION .....	4
2.1 WARNINGS .....	4
3. FEATURES AND ACCESSORIES .....	5
3.1 ADDITIONAL ACCESSORIES SOLD SEPARATELY .....	5
4. INSTALLATION .....	6
5. OPERATION .....	6
5.1 CONTROLLER POWER UP .....	6
5.2 SETTING THE BATTERY CHARGING PROFILE .....	7
5.3 BATTERY CHARGING PROFILE CHART .....	7
5.4 MAXIMUM POWER BOOST TECHNOLOGY™ .....	8
5.5 VIEWING THE CONTROLLER DISPLAY INFORMATION .....	8
5.6 ERRORS .....	9
6. DISPLAY SYMBOLS .....	10
7. USB CHARGING .....	11
8. SPECIFICATIONS .....	11
5.1 PORTABLE SOLAR KIT SPECIFICATIONS .....	11
5.2 SOLAR CONTROLLER SPECIFICATIONS .....	12
9. FREQUENTLY ASKED QUESTIONS .....	12
10. TROUBLESHOOTING .....	13
11. LIMITED WARRANTY .....	15



## 2.GENERAL INFORMATION





Welcome to the Go Power! Portable Solar Kit Installation Guide. Please read all instructions contained within this manual to gain a full understanding of how to install and use this product. Please visit [gpelectric.com](http://gpelectric.com) for the most current version of this manual.

Visit our Go Power! By Carmanah YouTube channel to watch a two minute video on setting up a portable solar kit.

Veillez visiter [gpelectric.com](http://gpelectric.com) pour la version française de ce manuel de l'utilisateur

Visite [gpelectric.com](http://gpelectric.com) para la versión en español de este manual del usuario

### 2.1 WARNINGS

	<b>Disconnect all power sources</b>	Electricity can be very dangerous. Take appropriate caution when making connections.
	<b>Battery and wiring safety</b>	Observe all safety precautions of the battery manufacturer when handling or working around batteries. When charging, batteries produce hydrogen gas, which is highly explosive. Ensure batteries are in a well-ventilated space, away from sparks for open flames.
	<b>Wiring connections</b>	Ensure all connections are tight and secure. Loose connections may generate sparks and heat. Be sure to check all connections before using the portable solar kit.
	<b>Observe correct polarity</b>	Reverse polarity of the battery terminals and array will cause the controller to give a warning tone. The controller will not function unless battery terminals are connected to a battery with proper polarity. Failure to correct this fault could damage the controller.
	<b>Do not exceed the GP-PWM-10 amp current and max voltage ratings</b>	The current rating of the solar system is the sum of the Maximum Power Current (Imp) of the solar PV strings in parallel. The resulting system Imp current is not to exceed 10A. The voltage of the array is the rated open circuit voltage (Voc) of the PV array and is not to exceed 28V. If your solar system exceeds these ratings, contact your dealer for a suitable controller alternative.

## 3.FEATURES AND ACCESSORIES

	Description	No	Description
1	Handle	10	Fuse
2	Latches	11	Protective carrying case
3	Aluminum frame	12	Corner protection
4	Aluminum support legs	13	Protective feet
5	Solar charge controller	14	Quick connect dust cover
6	Junction box	15	Ring terminals (for permanent mounting)
7	Cables	16	SAE Solar Plug (for connecting to RVs)
8	Battery clamps	17	2-Pin XLR Connector to Anderson Connector
9	Quick connect cable		

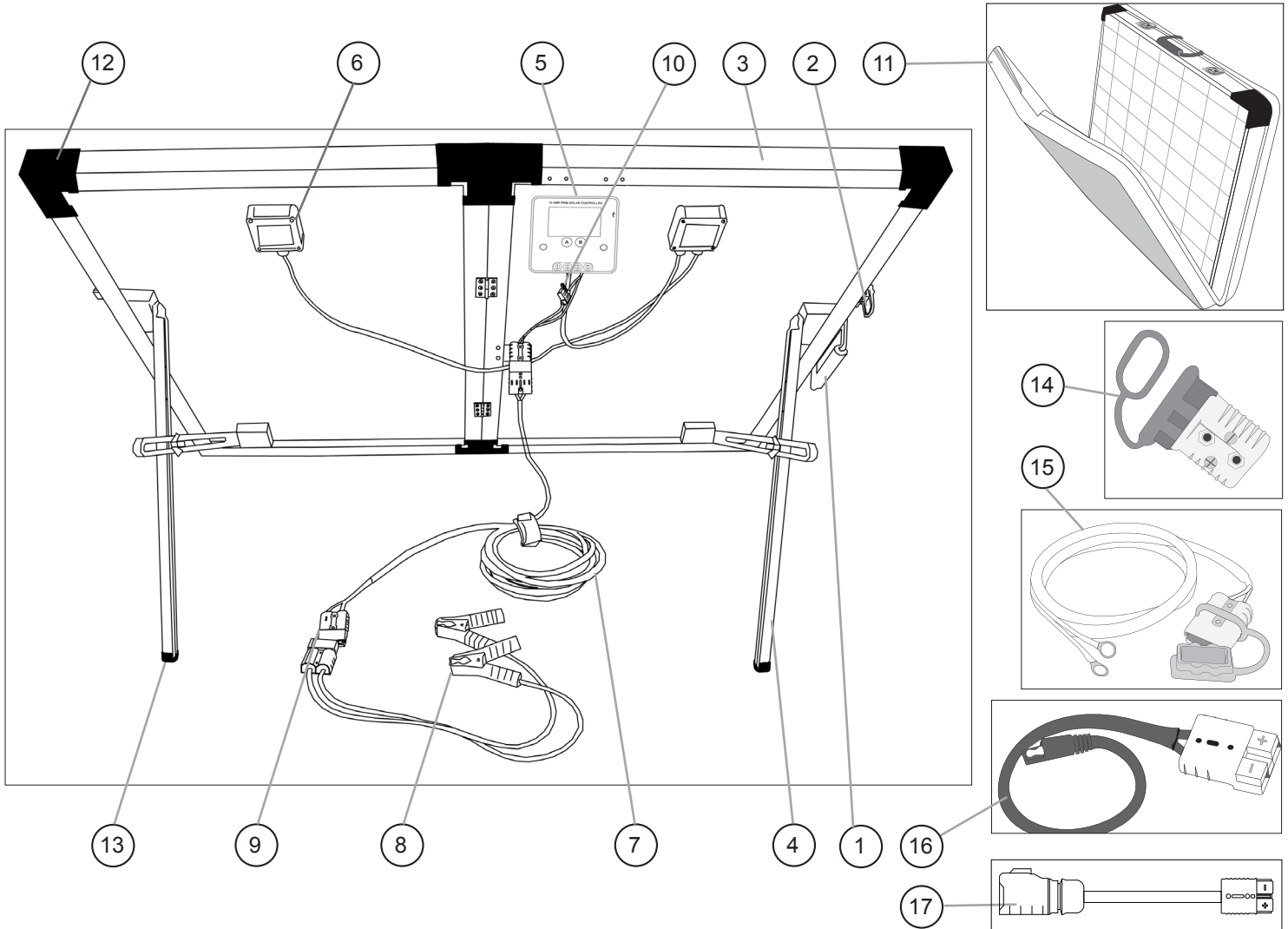

**3.1 ADDITIONAL ACCESSORIES SOLD SEPARATELY**

Visit [gpelectric.com](http://gpelectric.com) for product details.

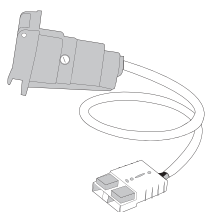

**GP-PSK-7PIN**  
 7 Pin Trailer Plug Adapter  
 - Use your existing trailer plug to access your battery for charging

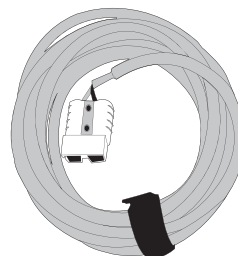

**GP-PSK-X30**  
 30' Extension Cable

- Park your RV in the shade and place your solar panel in the sun using this extension cable.



## 4.INSTALLATION

1. Locate a sunlit area, free from overhanging branches or obstructions.
2. Remove solar panel kit from carrying case.
3. Unclip the two latches on the side of the unit and fold the two panels outward.  
Extend the two support legs to their maximum length and lock in position.
4. Place solar panel facing the sun.

### Note

**Avoid any shading no matter how small. An object as small as a broomstick held across the solar module may cause the power output to be reduced. Overcast days may also cut the power output of the module.**

**To obtain maximum output it is suggested that the panel's direction be frequently adjusted to track the sun's movement throughout the day (southerly exposure).**

5. Connect battery clamps to the positive (red, +) and negative (black, -) battery terminals. Ensure that the connection is secure. Connect the battery clamp cable to the rest of the solar panel cable using the quick connect cable.



**Ensure the battery clamps do not come in contact with one another.**

**Do not let water come into contact with the controller.**

## 5.OPERATION

### 5.1 CONTROLLER POWER UP

When the Portable Solar Kit is connected to the battery, the controller will go into **Power Up** mode.

**Icons Displayed:** All segments of the numerical display;  
Backlight blinks

Depending on the battery voltage when the GP-PWM-10 Power Up occurs, the controller may do a Boost Charge or quickly go into Float Charge. The Charging Profile selected will commence the following day after a **Power Up** (refer to the Charging Profile Chart on page 4 for more details).

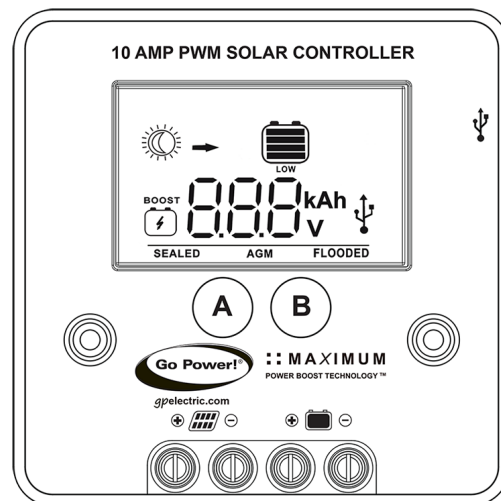

## 5.2 SETTING THE BATTERY CHARGING PROFILE

To select the battery charging profile, press and hold the **B Button**. This will cause the current battery type to flash.

Then, press the **B Button** to toggle through the profile options: Sealed/Gel, AGM or Flooded.

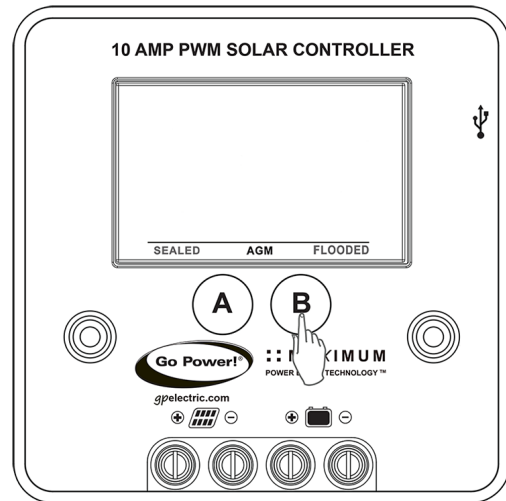

To confirm the battery profile, press and hold the **A Button** for 3 seconds.

**Non-volatile memory:** Any settings made on the GP-PWM-10 will be saved even when the power has been disconnected from the controller.

Refer to the Battery Charge Profile Chart below for details on each profile.

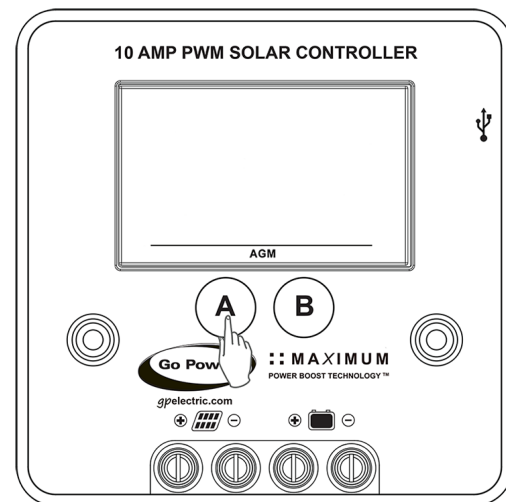

## 5.3 BATTERY CHARGING PROFILE CHART

BATTERY TYPE	SEALED/GEL	AGM	FLOODED
<b>Float Charge @ 25°C</b>		13.7V (+/- 0.1V)	
<b>Bulk/Absorption Charge @ 25°C:</b> Set to 30 minutes every morning. Applied for 1 hour if the battery voltage drops below 12.3 volts.	14.1V (+/- 0.1V)	14.4V (+/- 0.1V)	14.4V (+/- 0.1V)
<b>Equalization Charge:</b> Applied for 2 hours every 28 days and if the battery voltage drops below 12.1 volts.	N/A	N/A	14.9V (+/-0.1V)

If a charging cycle is unable to complete in a single day, it will continue the following day. The terms SEALED/GEL, AGM and FLOODED are generic battery designations. Choose the charging profile that works best based on your battery manufacturer's recommendations.

**Auto Equalize:** The controller has an automatic equalize feature that will charge and recondition your batteries once a month at a higher voltage to ensure that any excess sulfation is removed.

**Note** Auto Equalize is only available when Flooded batteries are selected.

## 5.4 MAXIMUM POWER BOOST TECHNOLOGY™

Maximum Power Boost Technology™ (MPBT) allows you to override the normal charging algorithm of the solar controller. MPBT is designed to be used before the end of the day, if you know you will require many loads through the night. This feature can also be used when you have just installed the solar controller, to put batteries on a boost charge up to 14.4V (Flooded and AGM) or 14.1V (Sealed/Gel) right away.

To activate, hold the **B Button** for 3 seconds. As long as there is full sunlight present, your battery voltage will be boosted (to 14.4V for Flooded and AGM and 14.1V for SEALED/GEL) for 30 minutes regardless of the battery's state of charge.

**Icons Displayed:** BOOST; Battery Symbol



**Do not use the Maximum Power Boost function more than twice a day as it could damage your batteries due to gassing.**

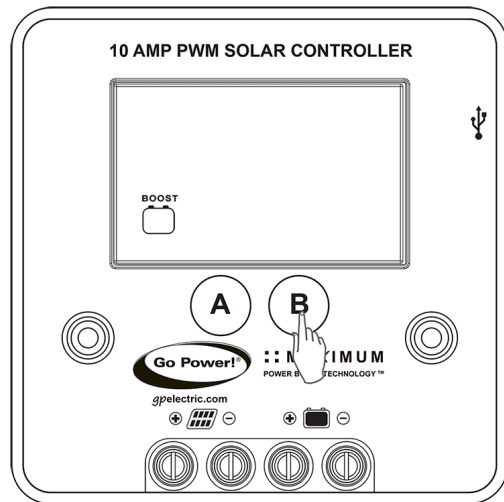

## 5.5 VIEWING THE CONTROLLER DISPLAY INFORMATION

To toggle between Battery Voltage, PV Charging Current and Battery State of Charge (SOC), press the **B Button**.

Push the **B Button** to show the battery voltage.

**Icons Displayed:** Battery SOC, Volt Symbol (V)

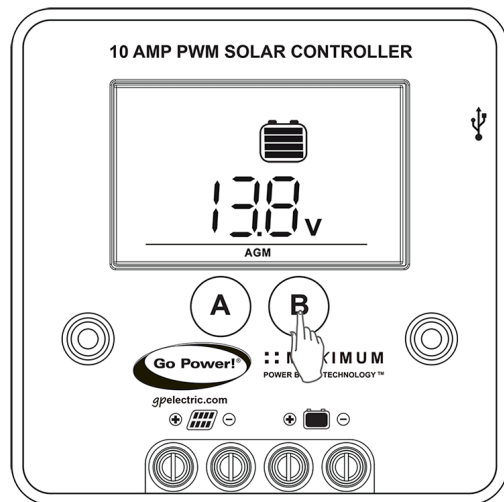

Push the **B Button** to show the PV charging current.

**Icons Displayed:** Arrow, Ampere Symbol (A), Battery SOC

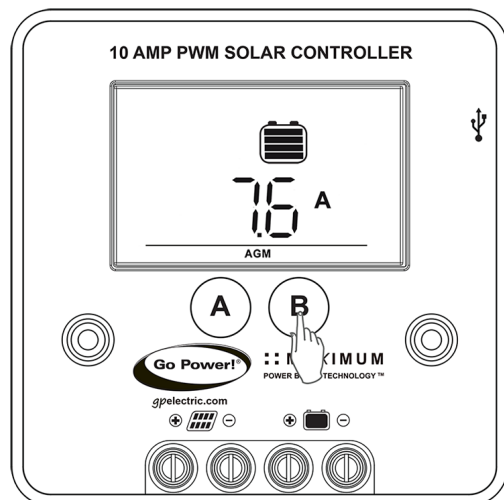



Push the **B Button** to show the battery state of charge (shown as a percentage).

**Icons Displayed:** Battery SOC, Percent Symbol (%)

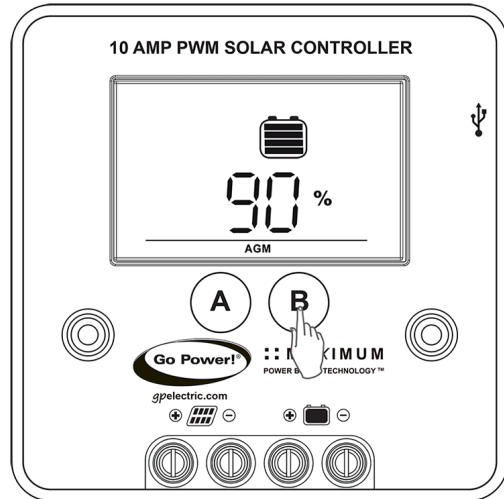

## 5.6 ERRORS

### Over Voltage

If the GP-PWM-10 experiences a battery over voltage (15.5V), the controller will stop operating and the display will begin to flash with all icons. The controller will resume operating when the error is cleared.

**Icons Displayed:** All symbols blinking

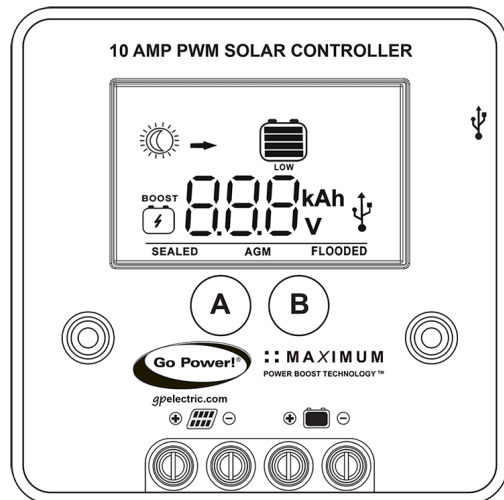







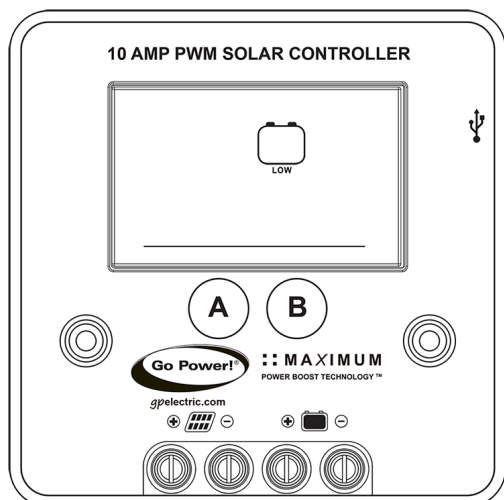

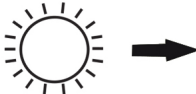
### Low Voltage

If the battery state of charge reaches 0%, the battery SOC symbol will show the text "LOW" beneath it. The controller will continue operating in this condition and will only stop operating if the battery voltage drops below 6 volts.

**Icons Displayed:** Battery SOC Symbol, LOW



SYMBOL	INDICATOR FOR:
	Day Time: PV Charge Current
	Night Time
	Battery Voltage
	Battery State of Charge
<b>SEALED</b>	Sealed/Gel Battery Type Selected
<b>AGM</b>	AGM Battery Type Selected
<b>FLOODED</b>	Flooded Battery Type Selected
	USB Charger On (when charger is off, no symbol will show)
<b>BOOST</b>	Controller tries to keep battery at Boost Voltage or higher
<b>LOW</b>	Battery Voltage is lower than 11.0V
Whole display will start to blink	Battery Voltage > 15.5V
BATTERY STATE OF CHARGE	
	Shows only after full Boost or Equalization Cycle
	$\geq 12.6V$
	$< 12.6V$ and $\geq 11.8V$
	$\leq 11.0V$
<b>LOW</b>	
100%	Shows only after full Boost or Equalization Cycle
90%	$\geq 12.8V$
$SOC = \frac{Battery\ Voltage - 11.0V}{1.8V} * 90\%$	$< 12.8V$ and $> 11.0V$
0%	$\leq 11.0V$



## 7.USB CHARGING

The GP-PWM-10 controller offers a standard USB connector for delivering 5V to small mobile appliances such as cell phones, tablets and small music players. This charging port is capable of supplying up to 800 mA of current.

**Icons Displayed:** USB symbol (appears only when port is active)

The controller disables the USB charger automatically if the battery voltage drops below 11.0V. If there is enough current from the PV panel/array available to charge the Battery to above 12.8V, the USB terminal will be enabled again.



**Do not connect the charging device anywhere else! USB-Negative contact is connected to battery negative.**

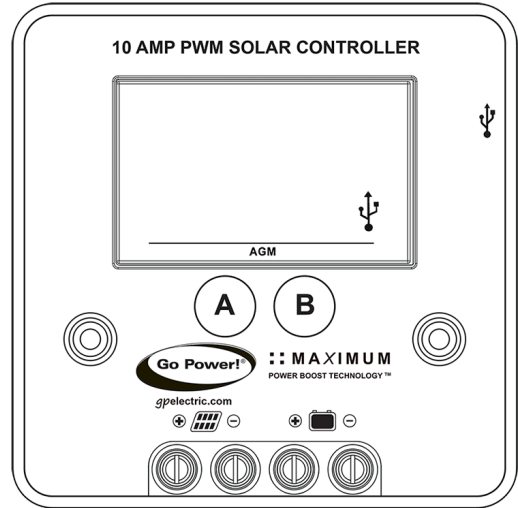

## 8.SPECIFICATIONS

### 8.1 PORTABLE SOLAR KIT SPECIFICATIONS

TYPE	MODULE SIZE (CLOSED)	MODULE SIZE (OPENED)	NET WEIGHT	MAX POWER	MAX POWER VOLTAGE	MAX POWER CURRENT	OPEN CIRCUIT VOLTAGE	SHORT CIRCUIT CURRENT
Module	(H) x (W) x (D)	(H) x (W) x (D)	lbs / kg	W	V	A	V	A
<b>80W</b> <b>(2x40W)</b>	21.57x19.80x2.75 in 548 x 503 x 70 mm	21.57 x 39.61 x 1.38 in 548 x 1006 x 35 mm	19.8 lbs / 9 kg	80	18	4.44	21.60	4.79
<b>120W</b> <b>(2x60W)</b>	32.44 x 19.8 x 2.75 in 824 x 503 x 70 mm	32.44 x 39.61 x 1.38 in 824 x 1006 x 35 mm	33 lbs / 15 kg	120	18	6.66	21.60	7.19



## 8.2 SOLAR CONTROLLER SPECIFICATIONS

DESCRIPTION	VALUE		
Nominal System Voltage	12V		
Max. Solar Array Current	10A		
Battery Voltage Range	6 - 15.5V		
Max. Solar Voltage	28V		
Operating Consumption (display backlight on)	15mA		
Operating Consumption (display backlight off)	6mA		
Bulk/Absorption Voltage (77°F / 25°C), 1 - 2h / Day	Sealed/ Gel 14.1V	AGM 14.4V	Flooded 14.4V
Float Voltage (77°F / 25°C)	13.7V		
Equalize Charging Voltage (77°F / 25°C) 2h / 28 Day or V < 12.1	14.9V		
Temperature Compensation	-13mV/°F / - 24mV/°C		
USB Charger	5V, 800mA		
Operating Temperature	- 40 to 185°F / - 40 to 85°C		
Display Operating Temperature	- 14 to 131°F / - 10 to 55°C		
Humidity	99% N.C.		
Protection	Battery Reverse Polarity, Solar Array Reverse Polarity, Over Temperature, PV Short Circuit, Over Current		
Dimensions (H x W x D)	3.94 x 4.02 x 1.14 in / 100 x 102 x 29 mm		
Weight	6.3 oz / 178 g		
Maximum Wire Gauge	#4 AWG		
Warranty	5 year		
Features	Accepts 160 watts of solar at 12 volts; 3 battery charging profiles; 4 stage charging; monthly equalize option; temperature compensated; RoHS compliant; Maximum Power Boost Technology™; display shows: charging current, battery voltage and battery state of charge		

### Note

The Solar Controller will not charge if the battery is below 6V. The total rated Maximum Power Current (Imp) of the PV input should not exceed 10A. The GP-PWM-10 will limit PV current above 10A. Although the controller will accept PV current greater than 10A for a short duration, damage may occur if the controller operates continuously with greater than 10A PV input.

## 9.FREQUENTLY ASKED QUESTIONS

Please visit [gpelectric.com](http://gpelectric.com) for the most up-to-date FAQs.

### Q1. It seems like my flooded batteries are losing water over time.

A. Flooded batteries may need to have distilled water added periodically to replace fluid loss during charging. Excessive water loss during a short period of time indicates the possibility of overcharging or aging batteries.

### Q2. When charging, my flooded batteries are emitting gas.

A. During charging, hydrogen gas is generated within the battery. The gas bubbles stir the battery acid allowing it to receive a more full state of charge. Ensure batteries are in a well-ventilated space.



# FREQUENTLY ASKED QUESTIONS

### Q3. My voltmeter shows a different reading than the GP-PWM-10 display

A. The meter value on the GP-PWM-10 display is an approximate reading intended for indication purposes only. There is an approximate 0.1 volt inherent error present that may be accentuated when compared with readings from another voltmeter.

There may be a slight difference between the battery voltage displayed on the GP-PWM-10 display and the battery voltage measured at the battery terminals. When troubleshooting using a voltmeter, check both the battery voltage at the controller terminals and battery voltage at the battery terminals. If a difference of more than 0.5 volts is noted, this indicates a large voltage drop possibly caused by loose connections, long wire runs, small wire gauge, faulty wiring, a faulty voltmeter or all the above. Check all connections.

## 10.TROUBLESHOOTING

### How to Read this Section

Troubleshooting Problems is split into three sub-sections, grouped by symptoms involving key components. A multimeter or voltmeter may be required for some procedures listed.



It is imperative that all electrical precautions outlined in this manual are followed. Even if it appears the system is not functioning, it should be treated as a fully functioning system generating live power.

Topic	Issue	Possible Cause	How to Tell	Remedy
<b>Problems with the Display</b>	Display is blank	Battery or fuse connection and/or solar array connection (daytime only) or battery or fuse connection (nighttime only)	<ol style="list-style-type: none"> <li>1. Check voltage at controller battery terminals with a voltmeter. Compare with voltage reading at the battery terminals.</li> <li>2. If there is no voltage reading at controller battery terminals, the problem is in the wiring between the battery and the controller. If the battery voltage is lower than 6 volts the controller will not function.</li> <li>3. For the solar array, repeat steps 1 and 2 substituting all references to battery terminals with solar array terminals.</li> </ol>	Check all connections from the controller to the battery including checking for correct wire polarity. Check that all connections are clean, tight, and secure. Ensure the battery voltage is above 6 volts.
	Display shows nighttime during the day	Panel is covered by something; PV panel is too dirty to supply a high enough voltage to charge the battery; PV panel is not connected	<ol style="list-style-type: none"> <li>1. Check the panel and ensure it is not obscured.</li> <li>2. Check that PV cables are connected to the controller.</li> </ol>	Clean the panel if it is dirty. Connect PV cables to controller if not connected.
<b>Problems with the Voltage</b>	Inaccurate voltage reading	Excessive voltage drop from batteries to controller due to loose connections, small wire gauge or both.	<ol style="list-style-type: none"> <li>1. Check the voltage at the controller battery terminals with a voltmeter and compare with the voltage reading at the battery terminals.</li> <li>2. If there is a voltage discrepancy of more than 0.5V, there is an excessive voltage drop.</li> </ol>	Check all connections from the controller to the battery including checking for correct wire polarity. Check that all connections are clean, tight and secure. Shorten the distance from the controller to battery or obtain larger gauge wire. It is also possible to double up the existing gauge wire (i.e. two wire runs) to simulate a larger gauge wire.



# TROUBLESHOOTING

Topic	Issue	Possible Cause	How to Tell	Remedy
	Current reading shows 0A at daytime, with clear sunny skies	Current is being limited below 1A as per normal operation or poor connection between solar array and controller.	<ol style="list-style-type: none"> <li>1. The State of Charge (SOC) screen is close to 100% and the Sun and Battery icon are present with an arrow between.</li> <li>2. With the solar array in sunlight, check voltage at the controller solar array terminals with a voltmeter.</li> <li>3. If there is no reading at the controller solar array terminals, the problem is somewhere in the wiring from the solar array to the controller.</li> </ol>	<p>Hold down the MAX BOOST Button for approximately 3 seconds to activate Maximum Power Boost. This will allow the controller to charge batteries to 14.4 +/- 0.1V (flooded and AGM) or 14.1 +/- 0.1V (Sealed/ Gel) with all current the solar array is producing.</p> <p>Check all connections from the controller to the array including checking for correct wire polarity. Check that all connections are clean, tight and secure. Continue with the solutions below for additional help on low current readings.</p>
<b>Problems with the Current</b>	Current reading is less than expected at daytime, with clear sunny skies	<ol style="list-style-type: none"> <li>1. Current is being limited below 1A as per normal operation.</li> <li>2. Incorrect series/parallel configuration and/or wiring connections and/or wire gauge.</li> <li>3. Dirty or shaded module or lack of sun.</li> <li>4. Blown diode in solar module when two or more modules are connected in parallel.</li> </ol>	<ol style="list-style-type: none"> <li>1. Battery State of Charge screen is close to 100% and the Sun and Battery icon are present with an arrow in between.</li> <li>2. Check that the modules and batteries are configured correctly. Check all wiring connections.</li> <li>3. Modules look dirty, overhead object is shading modules or it is an overcast day in which a shadow cannot be cast.</li> <li>4. Disconnect array wires from the controller. Take a voltage reading between the positive and negative array wire. A 12-volt array should have an open circuit voltage between 17 and 22 volts.</li> </ol>	<p>Reconnect in correct configuration. Tighten all connections. Check wire gauge and length of wire run.</p> <p>If dirty or obstructed, clean modules, clear obstruction or wait for conditions to clear.</p> <p>If the open circuit voltage of a non-connected 12-volt array is lower than the manufacturer's specifications, the module may be faulty. Contact the Go Power! Technical Support team as listed in section 10.1 for assistance.</p>



## 11.LIMITED WARRANTY

---

Go Power! warrants the solar panel of the Portable Solar Kit for 25 years, 1 year for the cable and components and 5 years for the solar controller. This warranty is valid against defects in materials and workmanship. It is not valid against defects resulting from, but not limited to:

- Misuse and/or abuse, neglect, or accident
- Exceeding the unit's design limits
- Improper installation, including, but not limited to, improper environmental protection and improper hook-up
- Acts of God, including lightning, floods, earthquakes, fire, and high winds
- Damage in handling, including damage encountered during shipment or installation

Visit [gpelectric.com](http://gpelectric.com) for additional product warranty information.

---

Refer to the troubleshooting or frequently asked questions section in this manual and/or read our "frequently asked questions" on [gpelectric.com](http://gpelectric.com) to troubleshoot any problem. If trouble persists:

1. Call your Go Power! Technical Support team (1-866-247-6527).
2. Return defective product to place of purchase.

